



Above: Dirtbag® installation shown on inclined hillside for maximum flow.

Disposal

Dispose of Dirtbag® as directed by the site engineer. If allowed, Dirtbag® may be cut open and the contents seeded after removing visible fabric. Dirtbag® is strong enough to be lifted with optional straps if it must be hauled away. Off-site disposal may be facilitated by placing Dirtbag® in the back of a dump truck or flatbed prior to use and allowing the water to drain from the bag while in place, thereby eliminating the need to lift Dirtbag®.

Dirtbag® Features:

- 1. High strength double stitched "J" type seams.
- 2. Sewn in spout.
- 3. High strength strapping for holding hose in place.
- 4. Hose opening accommodate up to 4" discharge hose.

Pump Discharge Hose

For optimal flow, install over straw or aggregate.

Aggregate or Straw Underlayment

ACF / SI Combine Forces for Solution Implementation

A Partnership for Water Quality



2831 Cardwell Road
Richmond, Virginia 23234
(800) 448-3636 • FAX (804) 743-7779

www.acfenvironmental.com

Distributed by:

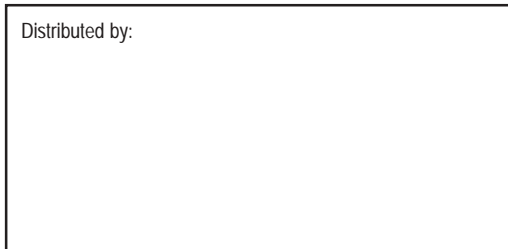

4019 Industry Drive
Chattanooga, TN 37416
(800) 621-0444 • FAX (423) 899-7619

www.sigeosolutions.com

Pumped Sediment Removal System

Whenever accumulated water must be pumped!

Protect the environment effectively and economically with Dirtbag®! Collect sand, silt and fines. Avoid silting streams, surrounding property and storm sewers. As more and more emphasis is put on saving our wetlands, regulations are becoming more stringent regarding the pumping of dirty water from holes around construction sites-such as foundations, pipe line construction, repairing municipal water/sewer lines, marine construction, utility, highway and site development areas. Dirtbag® applications are endless.

Use Recommendations

ACF Environmental manufactures Dirtbag® using a variety of nonwoven geotextile fabric manufactured by SI Geosolutions. The fabric properties on the Specifications page affirm the strength of Dirtbag® and are a result of tests conducted at on-site laboratories at the geotextile factory. All test methods are ASTM or industry standards.

Each standard Dirtbag® has a fill spout large enough to accommodate a 4" discharge hose. Straps are attached to secure the hose and prevent pumped water from escaping without being filtered.

Install Dirtbag® on a slope so that incoming water flows downhill through Dirtbag® without creating more erosion. Strap the neck of Dirtbag® tightly to the discharge hose. To increase the efficiency of filtration, place the bag on an aggregate or haybale bed to maximize water flow through the surface area of the bag.



Dirtbag® is full when it no longer can efficiently filter sediment or pass water at a reasonable rate. Flow rates will vary depending on the size of Dirtbag®, the type of ground, rock or other substance under the bag and the degree of the slope on which the bag lies. Under most circumstances Dirtbag® will accommodate flow rates of 1100 gallons per minute. Use of excessive flow rates or overfilling Dirtbag® with sediment will cause ruptures of the bags or failure of the hose attachment straps.



Easy To Use

First, Dirtbag® is easy to transport to the site. To install, simply unfold and insert up to 4" pump discharge the hose into the hand-sewn spout and secure with the attached straps. Pump dirty water into Dirtbag®. The bag collects the silt as the clean water gently filters out from all sides.

Compare Dirtbag® to the alternatives such as straw bale forts which are more cumbersome to transport, to build and to clean up afterward. And Dirtbag® poses no threat to the environment when disposed properly.



Dirtbag® Features

- Designed and produced from a variety of fabrics to meet engineering specifications for flow rates, strength and permeability.
- Stabilized to provide resistance to ultra-violet degradation.
- Meets municipal, state and Corps of Engineers specifications.
- Available in 10'x15', 12 ½' x 15' and 15' x 15' sizes. Custom sizes available.

Typical Dirtbag® Construction

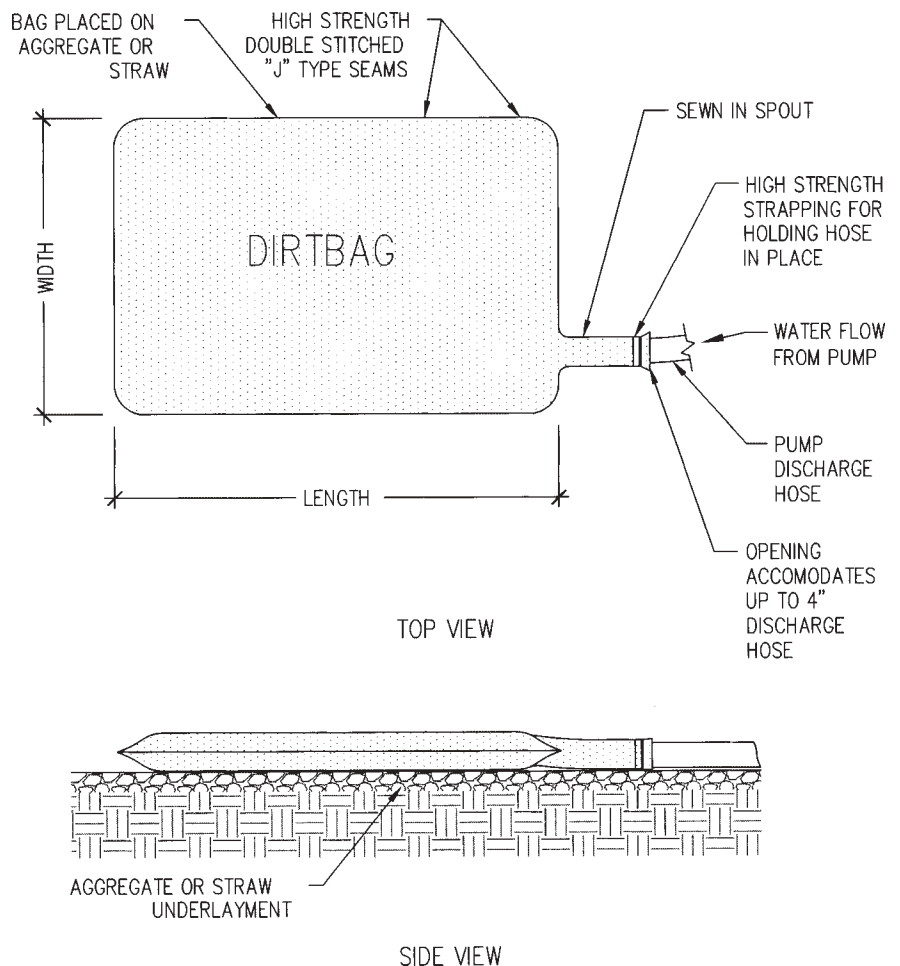

Dirtbag® Specification Control of Sediment In Pumped Water

All properties are Minimum Average Roll Value (MARV) except the weight of the fabric which is given for information only. Depending on soil conditions and filtration requirements, additional geotextile options are available. Please call our engineering staff for solutions.

1.0 Description

1.1 This work shall consist of furnishing, placing and removing Dirtbag® pumped sediment control device as directed by the design engineer or as shown on the contract drawings. Dirtbag® pumped-silt control system is marketed by:

*ACF Environmental, Inc.
2831 Cardwell Road
Richmond, Virginia 23234
Phone: 800-448-3636 • Fax: 804-743-7779
www.acfenvironmental.com*

2.0 Materials

2.1 Dirtbag®

2.1.1 Dirtbag® shall be manufactured using a polypropylene nonwoven geotextile from SI Geosolutions, then sewn into a bag with a double needle matching using a high strength thread.

*SI Geosolutions:
www.sigeosolutions.com
(800)621-0444*

2.1.2 Each standard Dirtbag® has a fill spout large enough to accommodate a 4” discharge hose. Straps are attached to secure the hose and prevent pumped water from escaping without being filtered.

2.1.3 Dirtbag® seams shall have an average wide width strength per ASTM D-4884 as follows:

Dirtbag® Style	Test Method	Test Method
Dirtbag® 53	ASTM D-4884	60 lbs./in
Dirtbag® 55	ASTM D-4884	100 lbs./in

Property	Test Method	Units	Test Results	
			Style 53	Style 55
Weight	ASTM D-3776	oz/lyd	8	10
Grab Tensile	ASTM D-4632	lbs.	205	250
Puncture	ASTM D-4833	lbs.	110	150
Flow Rate	ASTM D-4491	gal/min/ft²	110	85
Permittivity	ASTM D-4491	sec. ⁻¹	1.5	1.2
Mullen Burst	ASTM D-3786	lbs. in²	350	460
UV Resistant	ASTM D-4355	%	70	70
AOS % Retained	ASTM D-4751	US Sieve	80	100

3.0 Construction Sequence

3.1.1 To install Dirtbag® on a slope so incoming water flows downhill through Dirtbag® without creating more erosion. Strap the neck of Dirtbag® tightly to the discharge hose. To increase the efficiency of filtration, place the bag on an aggregate or haybale bed to maximize water flow through the surface area of the bag.

3.1.2 Dirtbag® is full when it no longer can efficiently filter sediment or allow water to pass at a reasonable rate. Flow rates will vary depending on the size of Dirtbag®, the type and amount of sediment discharged into Dirtbag®, the type of ground, rock or other substance under the bag and the degree of the slope on which the bag lies. Under most circumstances Dirtbag® will accommodate flow rates of 1100 gallons per minute. Use of excessive flow rates or overfilling Dirtbag® with sediment will cause the bag to rupture or failure of the hose attachment straps.

3.1.3 Dispose Dirtbag® as directed by the site engineer. If allowed, Dirtbag® may be cut open and the contents seeded after removing visible fabric. Dirtbag® is strong enough to be lifted with optional straps if it must be hauled away. Off-site disposal may be facilitated by placing Dirtbag® in the back of a dump truck or flatbed prior to use and allowing the water to drain from the bag while in place, thereby eliminating the need to lift Dirtbag®.

4.0 Basis of Payment

4.1 The payment for any Dirtbag® used during construction is to be included in the bid of overall erosion and sediment control plan unless a unit price is requested.